



## G r o w t h   C h a l l e n g e s !

Eight months have passed since the last edition in November 2006, marked by unrelenting growth. **Flotech's chief markets continue to boom** - Oil & Gas, propelled by the sustained high oil price, is giving oil companies the confidence to invest heavily in production equipment. The largest



*Stybarrow compressor being loaded*

orders for Flotech right now are compression systems for gas lift and re-injection on FPSO's (floating production storage & offloading vessels). More on that elsewhere- but this is exciting business utilising some

of the largest high speed reciprocating compressors in the world, with total power of up to 20,000 kW. (or 26,800 HP for the old school) Power generation also claims a lot of attention - especially in Pakistan where both gas fuelled recip engine and gas turbine plants are being installed at a heady rate. Flotech has more than 20 compressors installed or under construction in this market today.

While the traditional energy businesses are rocketing ahead, they also drag alternative fuels into the limelight - which we're happy about, as this brings even **more attention to Flotech's Greenlane®** biogas upgrading technology. The La Paloma project is the flagship for this concept worldwide, being by far the largest of its type - producing pure methane from municipal waste - used as fuel in Madrid's bus fleet. Other major projects in Lille (France) and Kobe, Japan are using this same proprietary technology, developed in-house by Flotech's engineers. Kallt® heat transfer has not been left behind in the rush - but these days we consume more Kallt® exchangers in our own compressors and Greenlane® plants than we have available to sell to other industries.

Revenues over the past two years have more than doubled, and the year ahead will see that growth sustained with the **order book filled well into 2008** already. All of this is not without challenge - finding competent and experienced people is an ever increasing challenge - but we've had very good results by recruiting in various countries. Managing project schedules and competition for resources is keeping management forever on

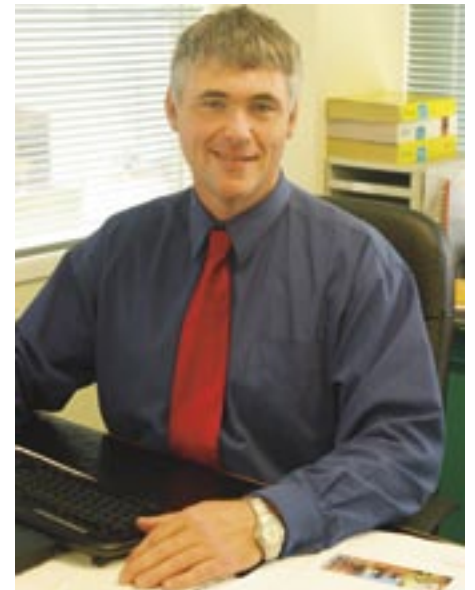

*John Dolan, Flotech General Manager Global Operations*

their toes. However I'm pleased to say that this is mainly resulting in the right kind of positive stress. We are blessed with **competent, diverse and very committed people** - and the current growth challenges are only making our team more enthusiastic! So to our customers, we will continue to say "yes" and welcome the opportunity to serve you better.

Last but not least, John Dolan has recently joined the Flotech Group as General Manager Global Operations. John comes onboard with a superb repertoire of experience in management spanning power utility, oil & gas fabrication, an industry training organisation and even extending to running engineering services for the NZ prison service! From all of us John, a warm welcome to the Flotech family!

**Steve Broadbent**  
*Group Managing Director*

### IN THIS ISSUE:

**Growth Challenges!**  
**Major New Zealand Project Secured**

**Project Management: the Key to Success**  
**La Paloma Biogas Upgrading System & Madrid Update**

**Stybarrow project & Singapore update**

# Major New Zealand Project Secured

Flotech has been awarded the contract to supply four compressor packages for the Kupe Gas Project in Taranaki.

The Kupe development includes both offshore platforms and onshore processing facilities. Flotech's contract with Origin Energy for the supply of 2x100% De-Ethaniser Overhead Compressors and 2x100% Flash

worked with the team at Independent Technology Limited in New Plymouth over a couple of months to develop a detailed and comprehensive tender document.

"Flotech had been following this project for at least a year and it was a clear company goal to secure this important New Zealand project," said Mr. Jan Ng, Project

applications has its own unique challenges. The De-ethaniser Overhead units have an operating suction temperature of  $-28^{\circ}\text{C}$  and design of  $-45^{\circ}\text{C}$  making material selection critical. The Flash Gas units

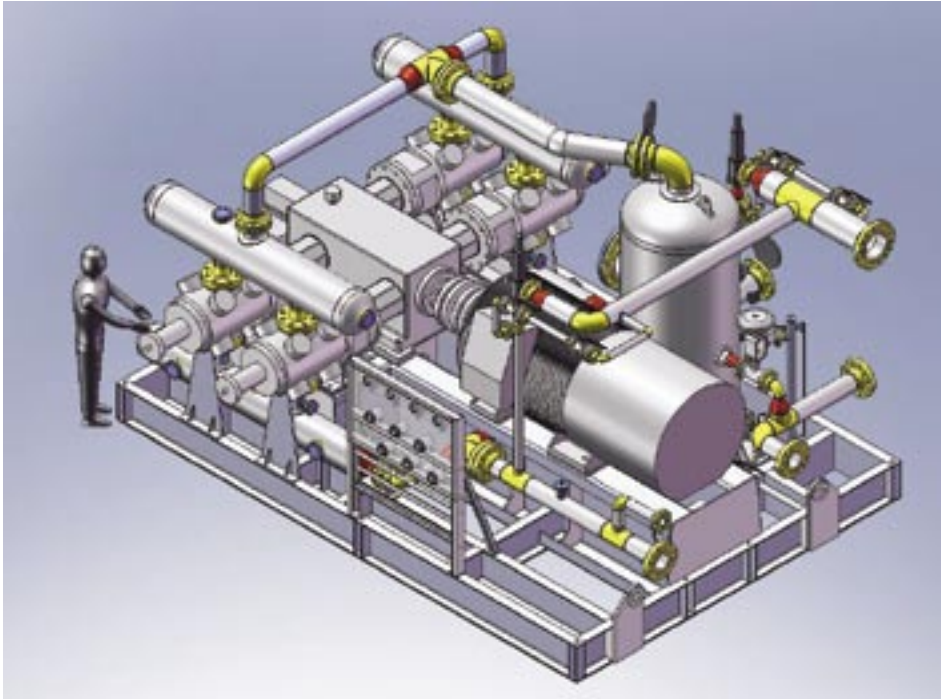

100% Flash Gas Compressor for the Kupe Gas Project in Taranaki

Gas Compressors for the onshore processing facilities makes it the company's largest project to date on home soil.

Flotech won the contract following a rigorous tendering process which included bid clarification meetings with the engineering consultant, Technip Oceania in Perth in January. Flotech

Manager. "Flotech are well known and respected internationally, and it has been a company objective in the last year to become better known in our back yard. Being a New Zealand supplier helped us with local content, which was an important factor in the contract award considerations."

Each of the two compression



Jan Ng - Kupe Project Manager

are NACE compliant with Variable Speed control to allow efficient turndown over the expected plant life. These packages also include large stainless steel scrubbers and fin fan coolers. The specifications are detailed and stringent – similar to those found in FPSO applications. Flotech are continuing with detailed design working in tandem with the ITL process team, which is proving to be a winning formula. With Flotech's growing experience in the supply of compressor packages for the offshore oil & gas market we are confident in meeting this NZ challenge.

The compressor packages are to be delivered to site on a split delivery February/March 2008.

## Project Management : the Key to Success

Another recent significant win for the compression engineering team at Flotech has seen the award of the Olowi Field Development contract by Norwegian company Kanfa AS. Flotech has a track record of successfully delivering projects to Kanfa and this placed it in a favourable position to win its biggest FPSO project to date. The Olowi Oil Field is located within the South Gabon sub-basin and covers an

area of 1300km<sup>2</sup> up to 50m deep.

The design, fabrication and supply of the 4 x 5MW HP Compression Units (GE manufactured, 6 Throw Reciprocating Compressors) and an LP Vapour Recovery unit, involves a variety of local and international suppliers as well as an innovative NZ based design team. This coupled with Flotech and the client being located near opposing ends of the globe creates complex scheduling and project management

challenges which impact on the efficient transfer of critical design and equipment information. The project is time critical with little room for delays in design, delivery and fabrication, all of which require careful planning to take advantage of overlaps wherever possible.

The logistics of such a project involves a large number of inputs and outputs each requiring dedicated tracking to meet the micro-deadlines

that are dictated by the overall delivery schedule. The careful management of such a myriad of parallel tasks was something Flotech identified early on would ensure the successful execution of the project. To this end, Flotech employed the services of NZ based professional engineering consultants, Beca, to oversee the project management and execution of the project. Beca has deployed a team consisting of a senior Project Manager and project engineers who work alongside Flotech personnel in the day to day running of the project.

Beca's project manager, Jorge Martinez, explains "the critical success factor of the team we have assembled to run this project has been the way the two companies have seamlessly merged their staff to work as one unit. Beca is fortunate in being able to hand select staff from a

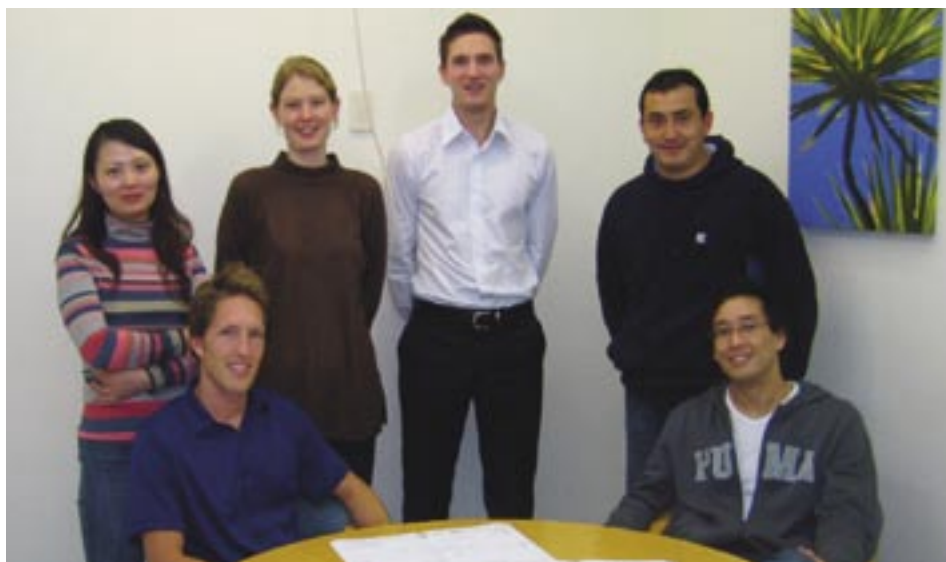

*Cherie, Jake, Lorraine, JP, Jorge & Kemlo - the Kanfa project team*

talented pool of people that are able to blend in with the highly capable engineers at Flotech and combine them to form a powerful and effective team, and have fun doing it".

The project is due for delivery in stages between December 2007 and January 2008 and is on track to match the needs of another satisfied client.

## La Paloma Biogas Upgrading System & Madrid update

**W**inning the contract for the La Paloma Biogas Upgrading System was a milestone for Flotech in its quest of becoming world leaders in biogas technology. The successful bid was just the beginning, it was essential that the Project Team led by Technical Director, Warwick Bethell, had the skills for working in Spain. To overcome the language difficulties, Flotech recruited two project engineers, Spanish chemical

engineer, Elsa Recio and Venezuelan mechanical engineer, Johann Hudde. Elsa and Johann have been invaluable in setting up Flotech Spain S.L.

The Project Team has dealt with the logistics in obtaining equipment from around the globe. The compression skids and the balance of components have been sea freighted from New Zealand and they have been consolidated with other parts obtained elsewhere.

Flotech has completed the fabrication of two Greenlane CSFR2000 Biogas Upgrading Systems. Last month assembly commenced on site and is scheduled for completion in September 2007. Commissioning of the Biogas Upgrading System will begin immediately after this. The plant will be the biggest Biogas Upgrading System in the world and will treat 4000m<sup>3</sup>/hour of raw biogas, which will provide gas for power generation and high pressure gas for injection into the Madrid gas network.

The timing of this project has come at an opportune time where New Zealand is receiving much publicity due to Emirates Team New Zealand's campaign 'to bring it [America's Cup] home' in Spain. New Zealand's high profile in Europe has proven to be fruitful for Flotech. Earlier in the year, El Pais, the most widely distributed daily newspaper in Spain, wrote an article on Flotech and its purpose in Madrid. This attracted the attention of other media sources and more importantly several energy based companies. This attention has enhanced Flotech's reputation throughout the continent where renewable energy is one of the fastest growing industries with its demand increasing everyday.



*The Madrid Project Team, Warwick Bethell, Elsa Recio and Johann Hudde.*

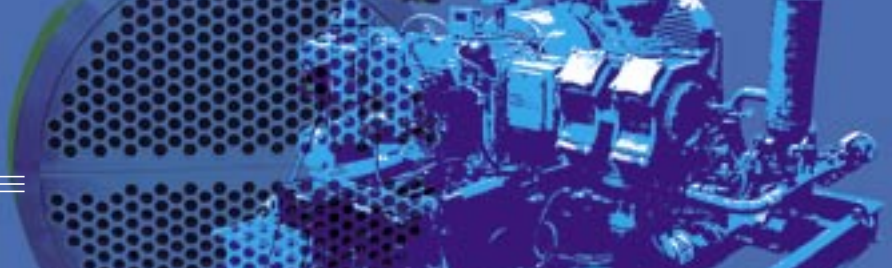

## Stybarrow Project & Singapore Update

The Flotech equipment packages for the Stybarrow project have now been loaded onto the FPSO at the shipyard in Singapore. The 2 x 200 tonnes MP compressor modules, the 1 x 100 tonne HP compressor module and the smaller tempered water skid have now been transported to the ship yard from the fabrication shop using specialist transportation equipment, and with production complete, and the packages loaded, interconnecting pipework and wiring is now underway. These machines have capacities of 23.6mmscfd and 39.6mmscfd respectively. The MPs are 4 stage, 6 cylinder double acting horizontally-opposed gas compressors with 3800 kW electric motor drives, lubrication systems, cooling systems



*Floating Production Storage & Offloading Vessel: the 1 x HP & 2 x MP compressors were loaded in June*

and liquid/gas separation. The HP compressor is a single stage 2 throw horizontally opposed and fully balanced gas compressor with

800kW electric drive, taking the gas from both the MP compressors and delivering the combined flow at 290 bar (g) for gas re-injection. GE Oil & Gas in Florence, Italy supplied the bare shaft compressors.

The compressor skids have been fabricated in Singapore and the Stybarrow Project is on schedule for the ship to depart from there in July. The success of this project has seen the formal registration of Flotech Singapore as a branch office.

In March, 3 x 3.2MW fuel gas booster compressors for the Korangi Power Station in Karachi, Pakistan also began construction in Singapore, as part of a fast track delivery project for Metka in Greece.

Flotech Singapore will be managing the fabrication of 4 x 5MW gas re-injection compressors for the Olowi field development, offshore Gabon, a contract secured earlier this year with Kanfa AS of Norway.



*Stybarrow HP compressor frame at Singapore fabrication yard*

BDA # 23876

**AUSTRALIA:**  
7 Railway Terrace,  
Rockingham, WA 6168.

**NEW ZEALAND:**  
47 Hastie Avenue,  
Mangere Bridge, Auckland.

**SINGAPORE:**  
6 Shenton Way #28-09,  
DBS Building Tower Two.

**SWEDEN:**  
Tullgårdsgatan 8,  
116 68 Stockholm.